

RoHS **Kxxx1G Series**

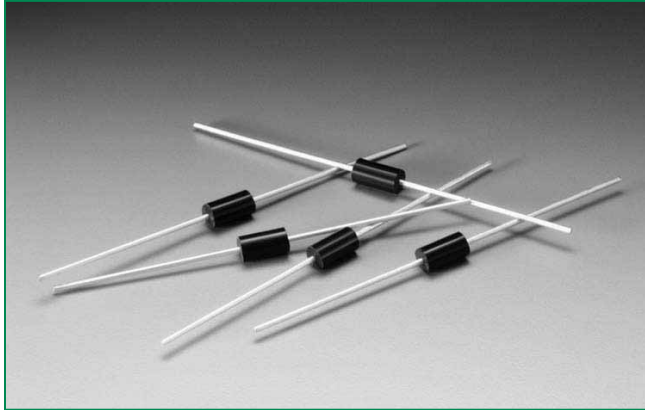

Schematic Symbol

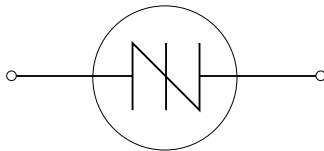

Applications

Typical application circuit presented in Figure 10 of this data sheet (Typical Metal Halide Ignitor Circuit).

Description

The Multipulse™ SIDAC is a voltage switch used in Metal-Halide lamp ignition circuits as well as High Pressure Sodium lamp ignition circuits for outdoor street and area lighting. This robust solid state switch is designed to handle lamp igniter applications requiring operation at ambient temperatures up to 90°C where igniter circuit components can raise SIDAC junction temperature up to 125°C, especially when the lamp element is removed or ruptured. Its excellent commutation time (t_{COMM}) makes this robust product best suited for producing multiple pulses in each half cycle of 50/60 Hz line voltage. The Multipulse™ SIDAC is offered in DO-15 axial leaded package.

Kxxx1G SIDAC has a repetitive off-state blocking voltage (V_{DRM}) of 180V to 270V minimum depending actual device type. Blocking capability is ensured by glass passivated junctions for best reliability. Package is epoxy encapsulation with tin-plated copper alloy leads.

Features

- AC circuit oriented
- **RoHS** Compliant
- Triggering Voltage of 200 to 380V

Electrical Specifications

| Symbol | Parameters | Test Conditions | Min | Max | Unit |
|-----------------|---|---|--------------------------|--------------------------|---------------------------|
| V_{BO} | Breakover/Trigger Voltage | K2201G K2401G K2501G K3601G | 200 220 240 340 | 230 250 280 380 | V |
| V_{DRM} | Repetitive Peak Off-State Voltage | K2201G K2401G K2501G K3601G | 180 190 200 270 | | V |
| $I_{T(RMS)}$ | On-State RMS Current, $T_J < 125^\circ\text{C}$ | 50/60Hz Sine Wave | | 1 | A |
| I_H | Dynamic Holding Current, $R=100\ \Omega$ | 50/60Hz Sine Wave | | 160 TYP | mA |
| R_S | Switching Resistance, $R_S = \frac{(V_{BO} - V_S)}{(I_S - I_{BO})}$ | 50/60Hz Sine Wave | | 100 | Ω |
| t_{COMM} | Commutation Time $T_J < 125^\circ\text{C}$ | See test circuit and waveform in Figure 9 | | 100 | μsec |
| I_{BO} | Breakover Current | 50/60Hz Sine Wave | | 10 | μA |
| I_{TSM} | Non-repetitive 1 cycle On-State peak value | 60Hz 50Hz | | 20.0 16.7 | A |
| di/dt | Critical Rate of Rise of On-State Current | | | 150 | A/ μsec |
| dv/dt | Critical Rate of Rise of Off-State Voltage | | | 1500 | V/ μsec |
| T_S | Storage Temperature Range | | -40 | +125 | $^\circ\text{C}$ |
| T_J | Max Operating Junction Temperature | | -40 | +125 | $^\circ\text{C}$ |
| $R_{\theta JL}$ | Thermal Resistance | Junction to lead | | 18 | $^\circ\text{C}/\text{W}$ |

Figure 1: Characteristics

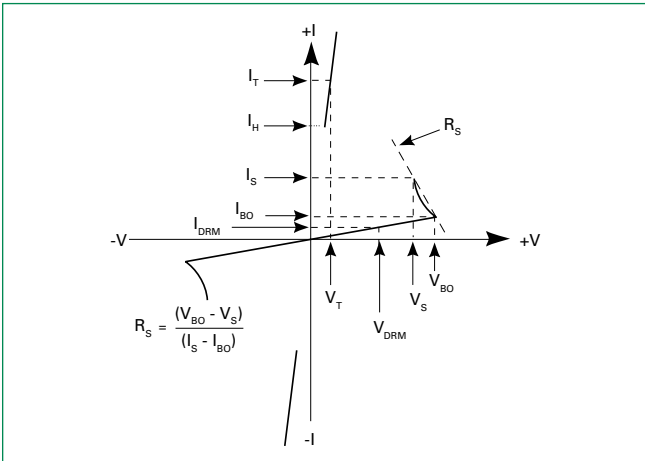

Figure 2: Maximum Allowable Lead/Tab Temperature vs. On-State Current

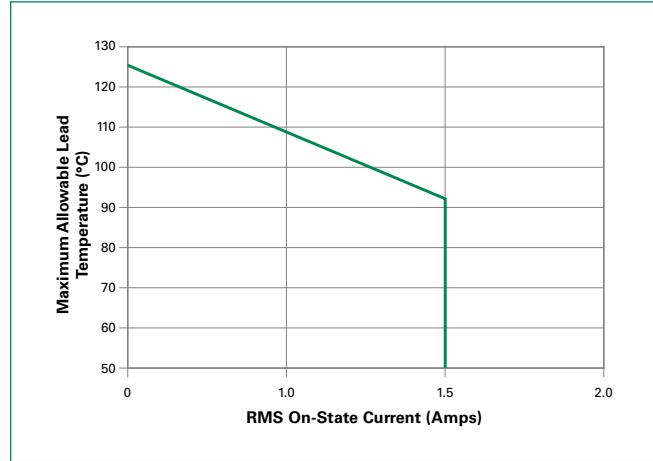

Figure 3: Power Dissipation (Typical) vs. On-State Current

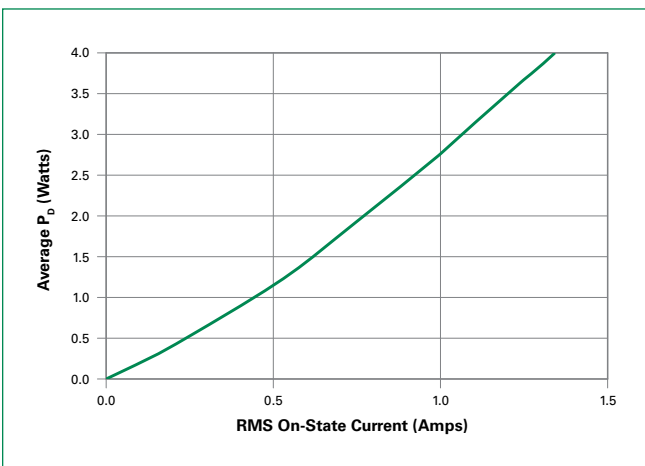

Figure 4: V_{BO} Change vs. Junction Temperature

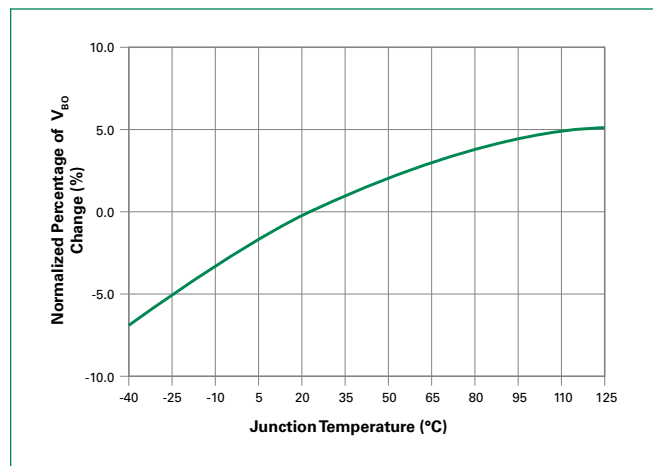

Figure 5: Pulse On-State Current Rating

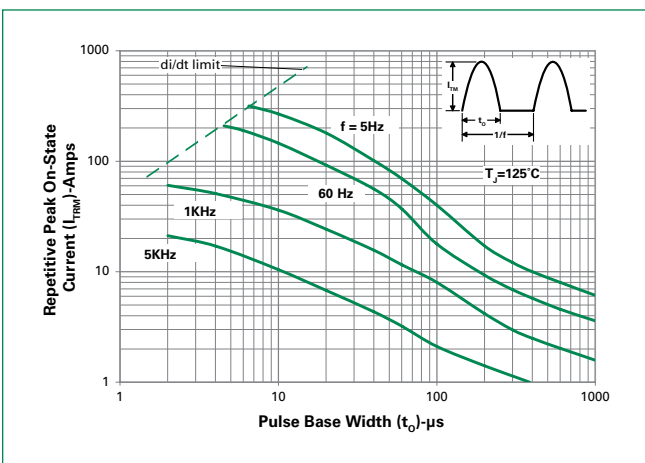

Figure 6: Maximum Allowable Ambient Temperature vs. On-State Current

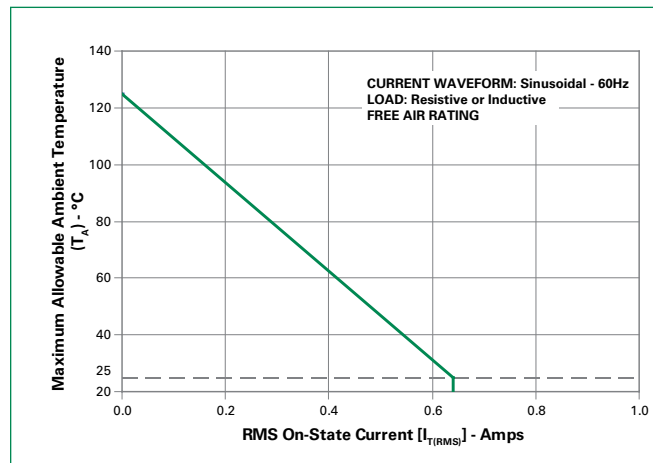

Figure 7: Peak Surge Current vs Surge Current Duration

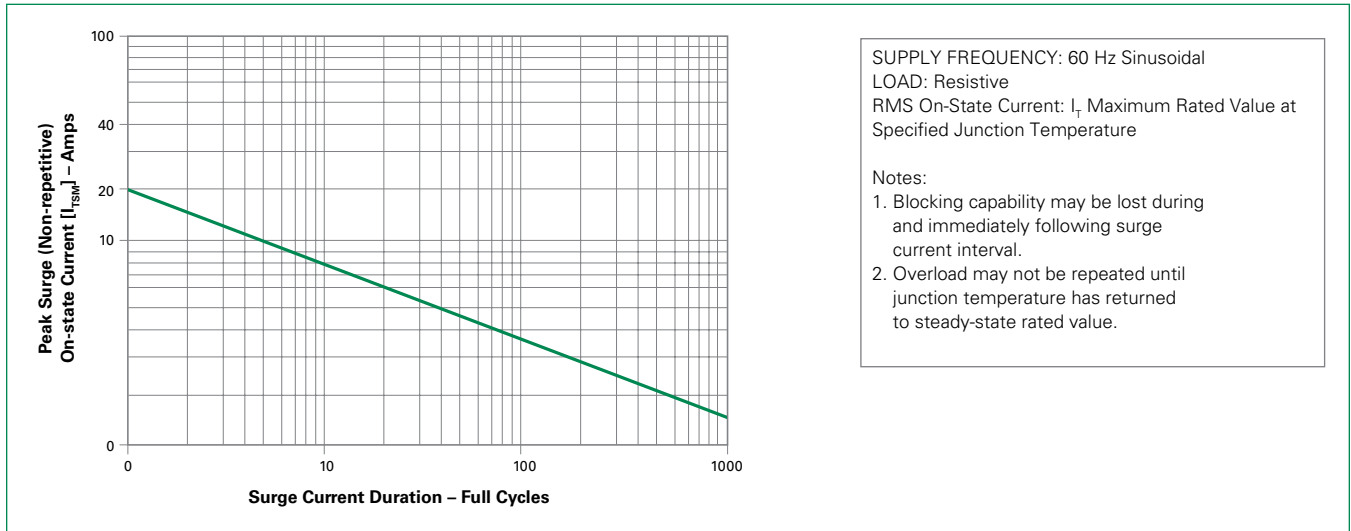

Figure 8: Typical On-State Voltage vs On-State Current

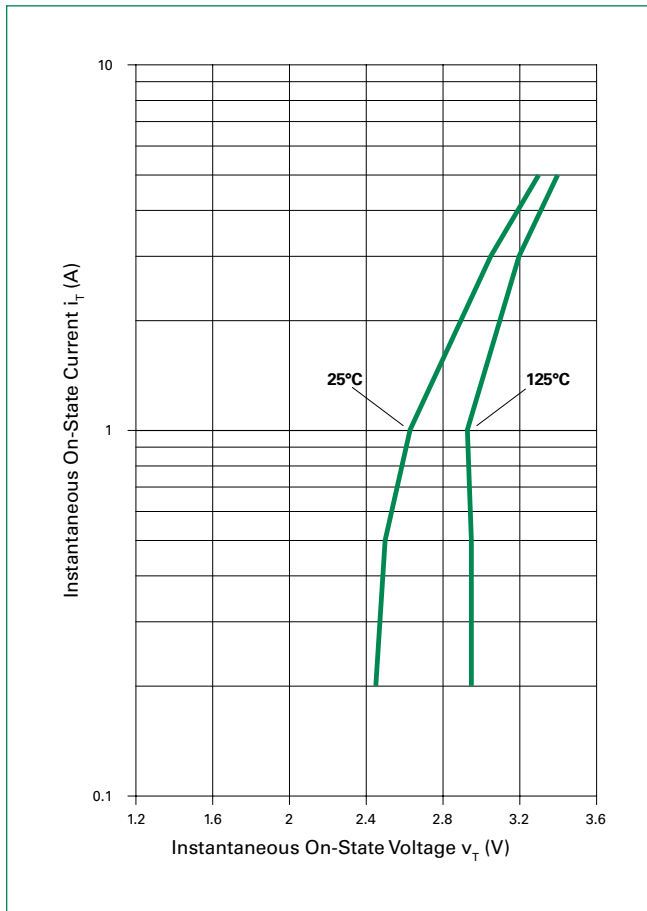

Figure 9: Multipulse™ SIDAC t_{COMM} Commutation Time

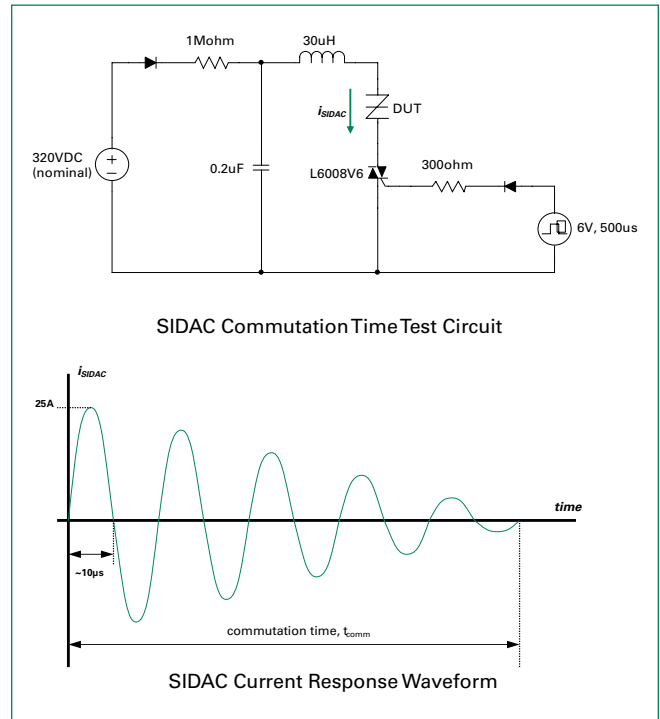
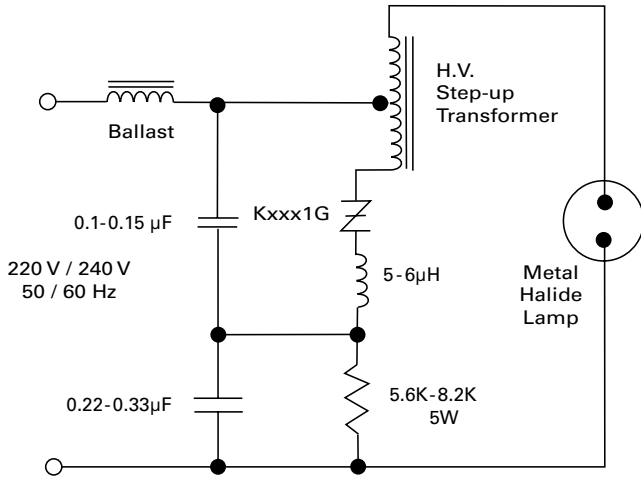

Figure 10: Typical Metal Halide Ignitor Circuit



Note: With proper component selection, this circuit will produce three pulses for ignition of metal halide lamp that requires a minimum of three pulses at 4kV magnitude and >1uSec duration each at a minimum repetition rate of 3.3kHz.

Soldering Parameters

| Reflow Condition | | Pb – Free assembly |
|--|------------------------------------|-------------------------|
| Pre Heat | - Temperature Min ($T_{s(min)}$) | 150°C |
| | - Temperature Max ($T_{s(max)}$) | 200°C |
| | - Time (min to max) (t_s) | 60 – 180 secs |
| Average ramp up rate (Liquidus Temp (T_L) to peak) | | 5°C/second max |
| $T_{s(max)}$ to T_L - Ramp-up Rate | | 5°C/second max |
| Reflow | - Temperature (T_L) (Liquidus) | 217°C |
| | - Temperature (t_L) | 60 – 150 seconds |
| Peak Temperature (T_p) | | 260 ^{+0/-5} °C |
| Time within 5°C of actual peak Temperature (t_p) | | 20 – 40 seconds |
| Ramp-down Rate | | 5°C/second max |
| Time 25°C to peak Temperature (T_p) | | 8 minutes Max. |
| Do not exceed | | 280°C |

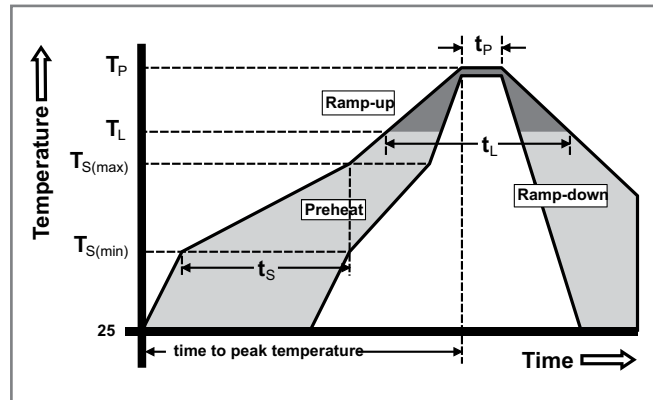

Physical Specifications

| | |
|------------------------|---|
| Terminal Finish | 100% Matte Tin Plated |
| Body Material | UL recognized epoxy meeting flammability classification 94V-0 |
| Lead Material | Copper Alloy |

| Package | Weight / unit (mg) |
|--------------|--------------------|
| DO-15 | 385 |

Design Considerations

Careful selection of the correct device for the application's operating parameters and environment will go a long way toward extending the operating life of the Thyristor. Overheating and surge currents are the main killers of SIDACs. Correct mounting, soldering, and forming of the leads also help protect against component damage.

Reliability/Environmental Tests

| Test | Specifications and Conditions |
|--|---|
| High Temperature Voltage Blocking | MIL-STD-750: Method 1040, Condition A Rated V_{DRM} (VAC-peak), 125°C, 1008 hours |
| Temperature Cycling | MIL-STD-750: Method 1051, 100 cycles; -40°C to 150°C, 15-minute dwell time |
| Temperature / Humidity | EIA/JEDEC: JESD22-A101 1008 hours; 160V - DC: 85°C; 85% relative humidity |
| High Temp Storage | MIL-STD-750: Method 1031 150°C, 1008 hours |
| Low-Temp Storage | -40°C, 1008 hours |
| Thermal Shock | MIL-STD-750: Method 1056 10 cycles; 0°C to 100°C; 5-minute dwell-time at each temperature; 10-sec (max) transfer time between temperature |
| Autoclave | EIA/JEDEC: JESD22-A102 168 hours (121°C at 2 ATMs) and 100% RH |
| Resistance to Solder Heat | MIL-STD-750: Method 2031 260°C, 10 seconds |
| Solderability | ANSI/J-STD-002: Category 3, Test A |
| Repetitive Surge Life Testing | Multi firings per half cycle at 60Hz in application circuit for 168 hours minimum |

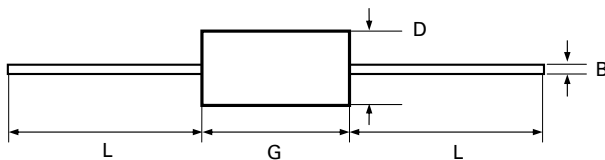
Dimensions — DO-15 (G Package)

| Dimension | Inches | | Millimeters | |
|-----------|--------|-------|-------------|-------|
| | Max | Max | Min | Max |
| B | 0.028 | 0.034 | 0.711 | 0.864 |
| D | 0.120 | 0.140 | 3.048 | 3.556 |
| G | 0.235 | 0.270 | 5.969 | 6.858 |
| L | 1.000 | | 25.400 | |

Product Selector

| Part Number | Switching Voltage Range | | Blocking Voltage | Packages |
|-------------|-------------------------|------------------|------------------|----------|
| | V_{BO} Minimum | V_{BO} Maximum | V_{DRM} | |
| K2201G | 200V | 230V | 180V | DO-15 |
| K2401G | 220V | 250V | 190V | DO-15 |
| K2501G | 240V | 280V | 200V | DO-15 |
| K3601G | 340V | 380V | 270V | DO-15 |

Packing Options

| Part Number | Package | Packing Mode | Base Quantity |
|-------------|---------|--------------|---------------|
| Kxxx1G | DO-15 | Bulk | 1000 |
| Kxxx1GRP | | Tape & Reel | 5000 |

Note: xxx = voltage

DO-15 Embossed Carrier RP Specifications

Meets all EIA RS-29-6 Standards

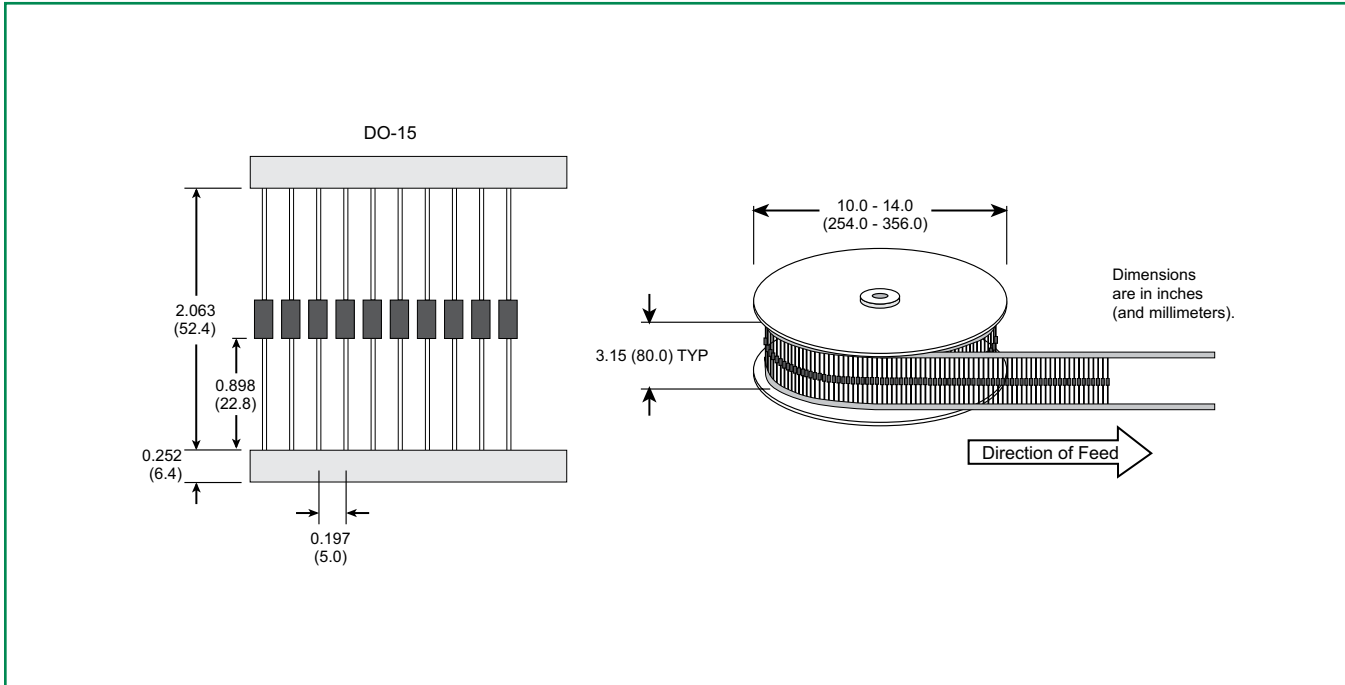

Part Numbering System

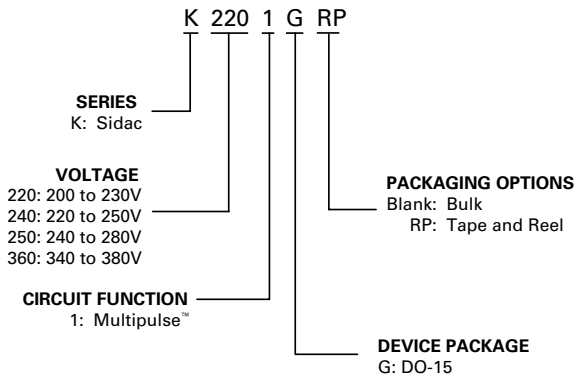

Part Marking System

