

Single-Package Regulator series

# 0.175A/0.19A Output Fully Integrated Step Up/Down Charge pump regulator



## BZ1A5001GM

### General Description

BZ1A5001GM is a Single-Package Regulator with integrated peripheral parts. The time and effort of the design can be saved. It can contribute in shortening the design time of portable devices and industrial apparatus, parts count reduction, and miniaturization. BZ1A5001GM is based on Dual Phase Step Up/Down Charge pump Regulator IC. Output Voltage and Current Rating of 5.0V/0.175A and 4.5V/0.19A can be chosen by VSEL. Additionally, Oscillation frequency of 642KHz and 238KHz can be chosen by FSEL. It is the best power supply for HDMI, USB on the go, and LED torch Light for mobile phone. Brightness can be adjusted by EN.

### Features

- No external parts needed
- Reverse current prevention from an output
- Selectable Output Voltage
- Selectable Oscillation Frequency
- 0uA typical standby current
- Built-in Over Current Protection (OCP)
- Built-in Thermal Shut Down circuit (TSD)
- Ultra small package

### Application

Smart Phone, Mobile Phone, Portable Audio Player, Portable Devices, POL Regulator, HDMI Devices, USB on the go Devices, LED torch Light Devices

### Package

BGA-MD W(Typ.) x D(Typ.) x H(Max.)  
2.30mm x 2.40mm x 1.00mm

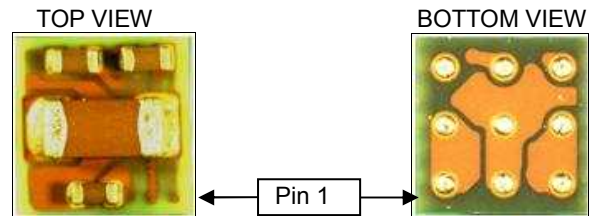

### Pin Configuration (Top View)

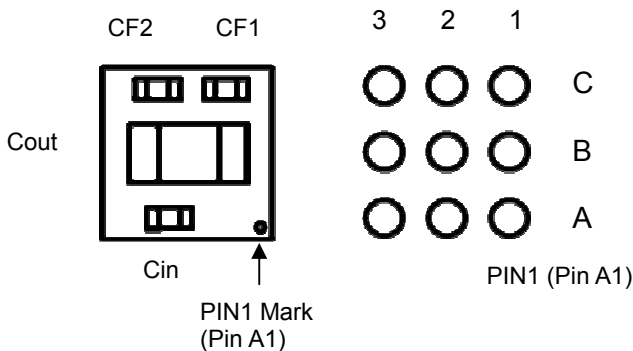

Figure 1. Pin Configuration  
(Please check p.6/11 for details)

### Typical Application Circuit

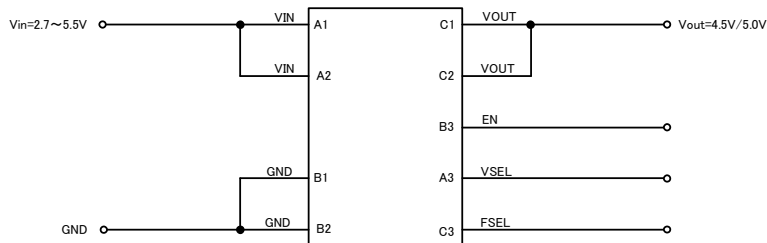

Figure 2. Typical Application Circuit

### Pin description

Pin No	Symbol	Name	Function
1	A1	VIN	Power supply Input Pin
2	A2	VIN	Power supply Input Pin
3	A3	VSEL	Output Select Pin
4	B1	GND	GND Pin
5	B2	GND	GND Pin
6	B3	EN	Enable Pin
7	C1	VOUT	Output pin
8	C2	VOUT	Output Pin
9	C3	FSEL	Frequency Select Pin

●Block Diagram

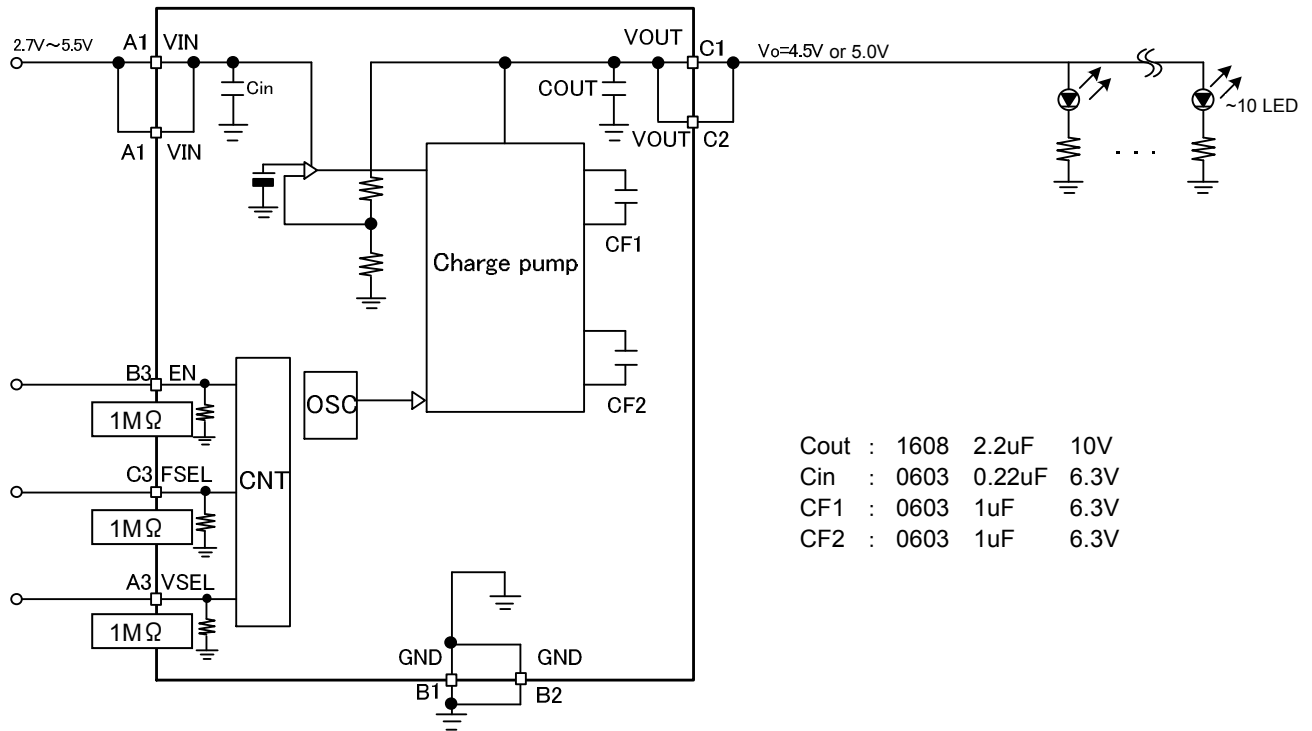

Figure 3. Block Diagram

●Description of Block

1. ON/OFF Control

The voltage level of EN Pin controls whether the device is turned ON or OFF.

EN = "H" : Active

EN = "L" : Standby Circuit current is 0uA

2. Low Ripple voltage by Dual Phase Charge pump

Low Ripple output voltage is possible through the use of Dual Phase Charge pump & Fixed frequency. Ripple has significantly reduced compared to previous Charge-Pump regulators.

3. Selectable Frequency

The voltage level of FSEL pin selects the oscillation frequency.

FSEL="H":642kHz

FSEL="L":238kHz

4. Power Dissipation

Power Dissipation is calculated as follows.

$$P_D = P_{IN} - P_{OUT}$$

$$= (V_{IN} \times I_{IN}) - (V_O \times I_O) [W]$$

Please set up Vin & Io not to exceed the allowable power dissipation.

Since it is greatly dependent also on the PCB layout, the allowable power dissipation should consider the heat dissipation characteristic of the PCB layout design.

5. Short circuit protection

Protects the device when the output is short-circuited to the ground by limiting the output current.(TYP:150mA)

Once short-circuit is cleared, normal LSI operation is resumed (automatic return).

OCP point is 800mA(Typ).

6. Thermal shutdown

When the chip setting temperature is 185°C (typ) or more, the thermal shutdown function is activated to turn off the charge pump circuit.

When this temperature falls below the thermal detection temperature, normal LSI operation is resumed. Accordingly, the following ON and OFF operations are repeated as thermal operations unless the primary cause is resolved.

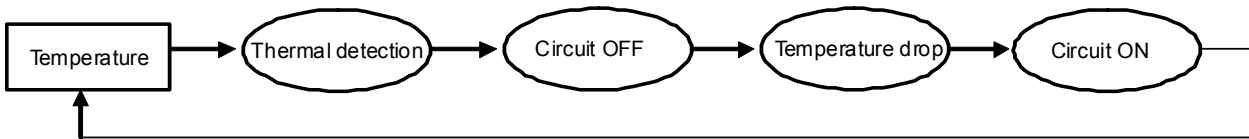

Fig.4 Thermal detection loop

7. Setting the LED current

The LED current is set as follows.

The constant must be determined, considering variations in resistance and LED.

$$I_{LED} = \frac{V_{OUT} - V_F}{R} \text{ [A]}$$

$V_{OUT}$  : BZ1A5001GM Output Voltage

$V_F$  : LED's  $V_F$

R : LED setting register

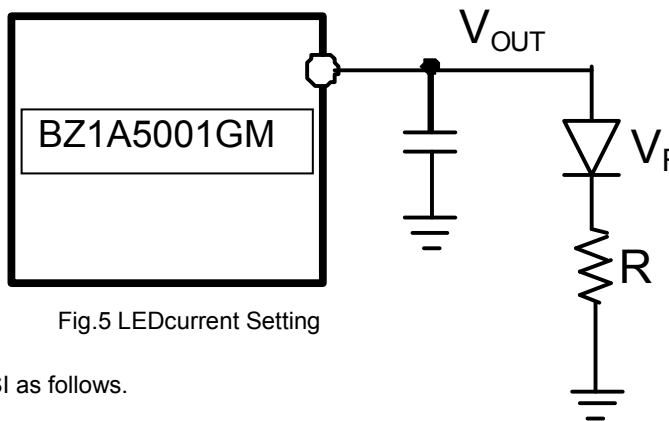

Fig.5 LEDcurrent Setting

8. Brightness control

Brightness control takes place in this LSI as follows.

a) PWM

The EN pin is turned ON or OFF repeatedly via the PWM signal.

It is recommended that the PWM frequency is 100Hz or below. This frequency must be determined, fully evaluating the linearity of brightness to the PWM duty. If the rush current causes a problem when the EN pin is turned ON, brightness control must be carried out by switching the LED current as discussed on the next section.

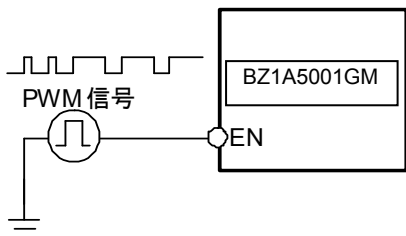

Fig.6 PWM Brightness control

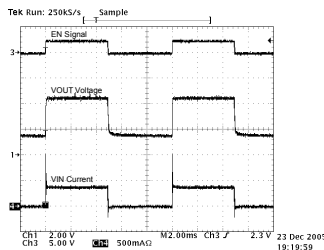

Fig.7 VIN=4.5V100Hz ON/OFF

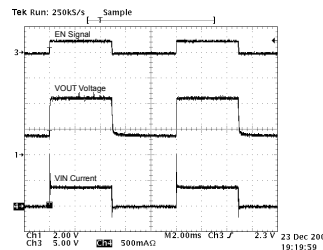

Fig.8 VIN=5.0V100Hz ON/OFF

b) Switching the LED Current

Switching the LED current takes place via the external switch.

The constant must be determined, considering the ON resistance of the switch transistor.

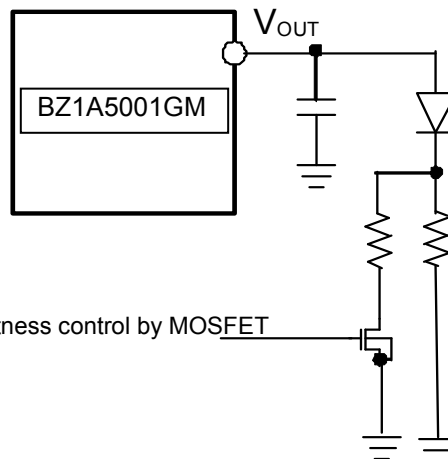

Fig.9 Brightness control by MOSFET

● Absolute Maximum Rating (Ta=25°C)

Parameter	Symbol	Ratings	Unit
Power supply voltage	VIN	6.3	V
Power Dissipation	Pd	0.75(*1)	W
Operating Temperature	Topr	-30 ~ +85	°C
Storage Temperature	Tstg	-55 ~ +125	°C
Junction Temperature	Tjmax	+125	°C

(\*1)Reduced by 7.6mW/°C for each increase in Ta of 1°C over 25°C. (During ROHM standard board implementation)

● Operating Range (Ta=25°C)

Parameter	Symbol	Limits			Unit
		Min	Typ	Max	
Power supply voltage	VIN	2.7	-	5.5	V
Max Current (t=500ms Duty=20%)	Io(pulse)	-	-	200	mA
Start up Time (EN⇒Vo to 80%)	Tr	-	150	300	us
Off Time (EN⇒Vo to20%)(*2)	Tf	-	-	1	ms

(\*2) Value when a 200 Ω discharge resistor is connected.

● Electrical Characteristics (Ta=25°C, VIN = 3.6V, unless specified)

Parameter	Symbol	Limits			Unit	Condition
		Min	Typ	Max		
<b>【Regulator block】</b>						
Output Voltage 1	VOUT1	4.80	5.00	5.20	V	VSEL=High
Output Voltage 2	VOUT2	4.27	4.50	4.73	V	VSEL=Low
Output Current 1	IOUT1	-	-	175	mA	VSEL=VIN, 3.2 < VIN
Output Current 2	IOUT2	-	-	190	mA	VSEL=0V, 3.2V < VIN
Output Current 3	IOUT3	-	-	60	mA	VSEL=VIN, 3.2V > VIN
Output Current 4	IOUT4	-	-	120	mA	VSEL=0V, 3.2V > VIN
<b>【Oscillator Brock】</b>						
Frequency 1	fosc1	-	238	-	kHz	FSEL=Low
Frequency 2	fosc2	-	642	-	kHz	FSEL=High
<b>【Control Pin Block】</b>						
EN Pin Control Voltage	Active	VENH	1.3	-	VIN	V ON
	OFF	VENL	0	-	0.4	V OFF
VSEL Pin Control Voltage	5.0V	VSELH	1.3	-	VIN	V Vout=5V
	4.5V	VSELL	0	-	0.4	V Vout=4.5V
FSEL Pin Control Voltage	High Freq	FSELH	1.3	-	VIN	V OSC=642kHz
	Low Freq	FSELL	0	-	0.4	V OSC=238kHz
<b>【Efficiency】</b>						
Efficiency 1	Eff1	-	75	-	%	FSEL=Low : Iout=60mA
Efficiency 2	Eff2	-	74.5	-	%	FSEL=High : Iout=60mA
<b>【Circuit Current】</b>						
Circuit Current 1	IINS1	-	1.4	2.0	mA	FSEL=Low
Circuit Current 2	IINS2	-	3.0	4.2	mA	FSEL=High
Shut down Current	SHD	-	0	2	uA	EN=0V

© This product is not designed to protect itself against radioactive rays.

\*1) Please design a VIN condition and a load current not to exceed Pd of the LSI.

●Reference data

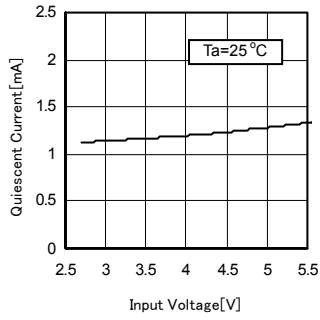

Fig.10 Quiescent Current 1

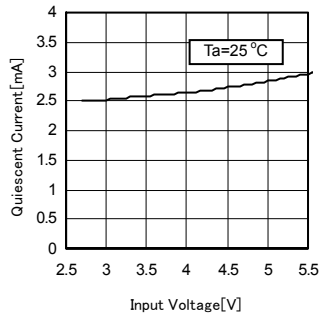

Fig.11 Quiescent Current 2

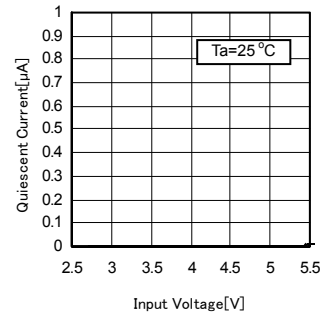

Fig.12 Quiescent Current 3

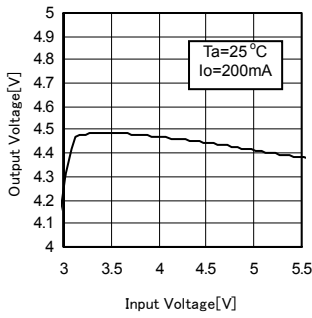

Fig.13 Line Regulation (VSEL = 0V)

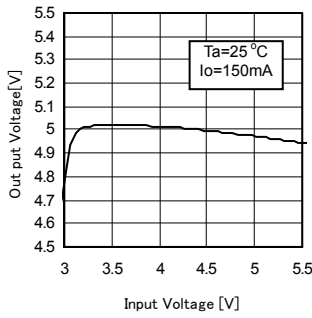

Fig.14 Line Regulation (VSEL = VIN)

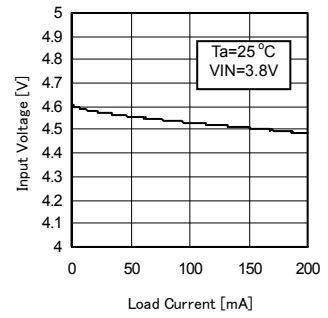

Fig.15 Load Regulation (VSEL = 0V)

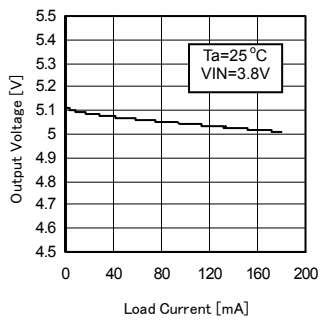

Fig.16 Load Regulation (VSEL = VIN)

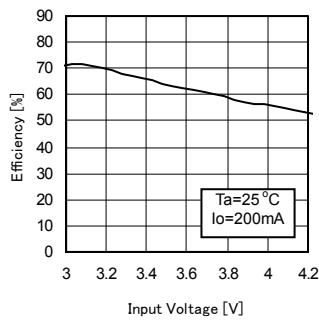

Fig.17 Efficiency vs. Input Voltage (VSEL = 0V)

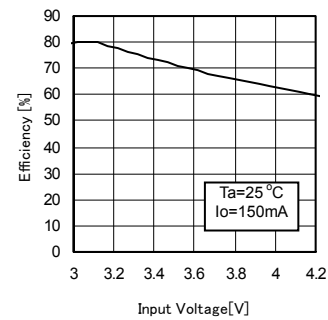

Fig.18 Efficiency vs. Input Voltage (VSEL = VIN)

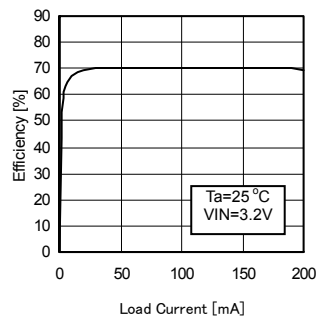

Fig.19 Efficiency vs. Load Current (VSEL = 0V)

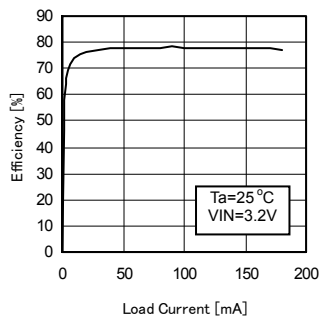
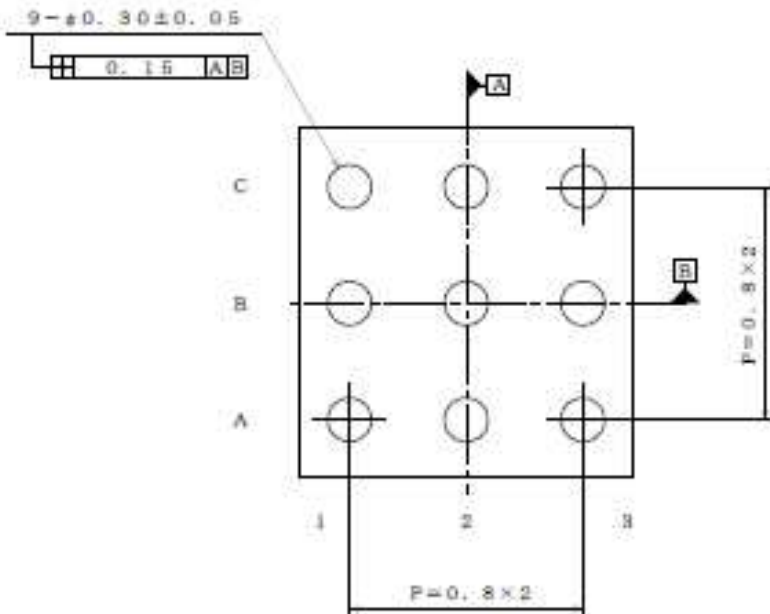
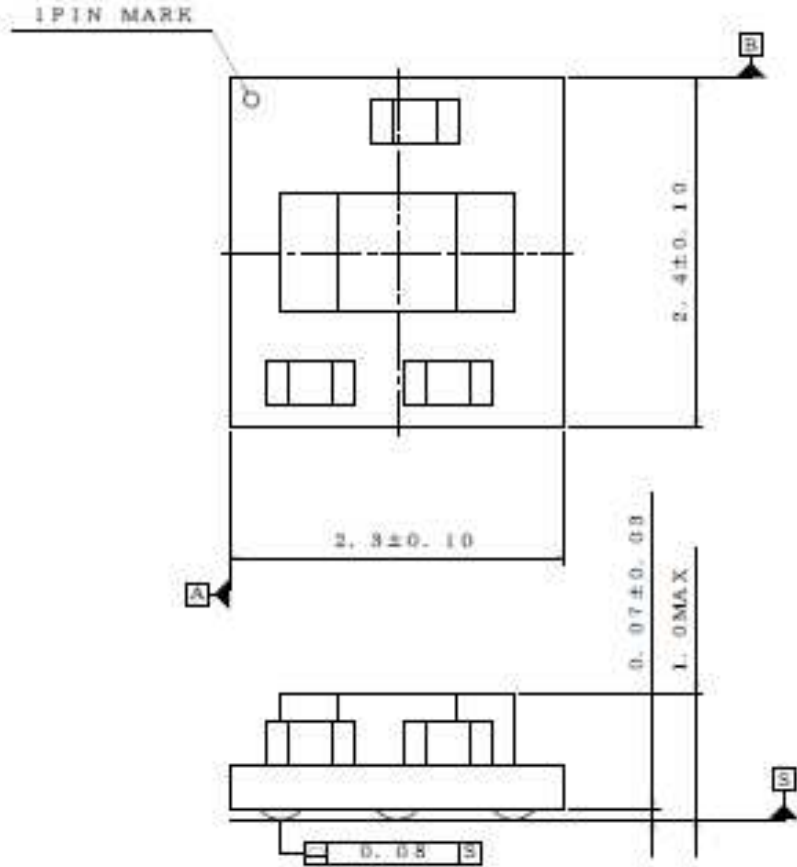
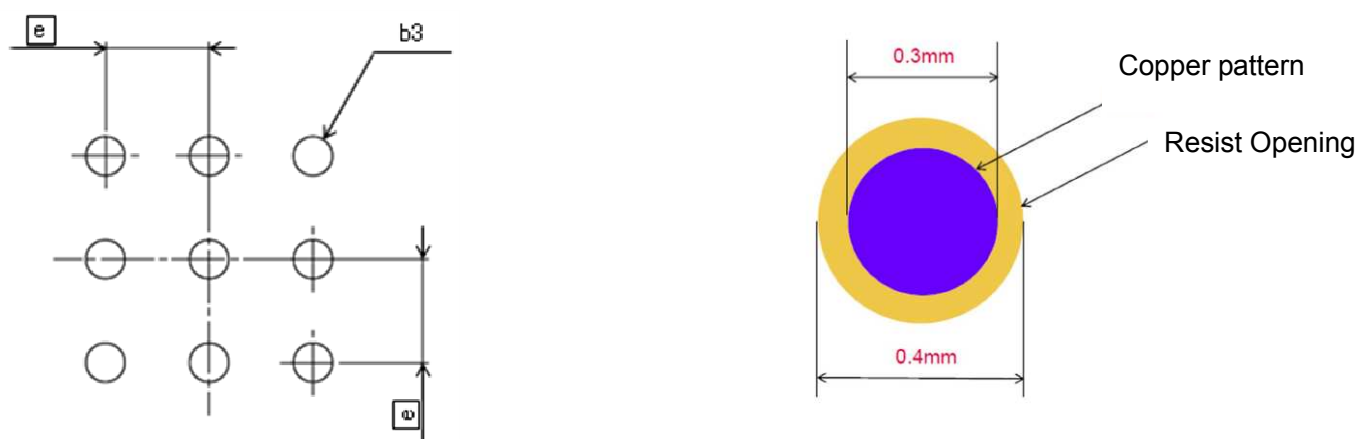

Fig.20 Efficiency vs. Load Current (VSEL = VIN)

●External Dimensions (Unit: mm)



●PCB layout



Symbol	Typical Size
e	0.80
b3	Φ 0.30

Fig..21 Recommended PCB Layout Pattern (TOP VIEW)

●Operational Notes

- (1) Absolute Maximum Ratings  
Operating the IC over the absolute maximum ratings may damage the IC. In addition, it is impossible to predict all destructive situations such as short-circuit modes or open circuit modes. Therefore, it is important to consider circuit protection measures, like adding a fuse, in case the IC is expected to be operated in a special mode exceeding the absolute maximum ratings.
- (2) Reverse connection of power supply  
Connecting the power supply in reverse polarity can damage the IC. Take precautions against reverse polarity when connecting the power supply, such as mounting an external diode between the power supply and the IC's power supply terminals.
- (3) Power supply lines  
Design the PCB layout pattern to provide low impedance ground and supply lines. Separate the ground and supply lines of the digital and analog blocks to prevent noise in the ground and supply lines of the digital block from affecting the analog block. Furthermore, connect a capacitor to ground at all power supply pins. Consider the effect of temperature and aging on the capacitance value when using electrolytic capacitors.
- (4) Ground Voltage  
The voltage of the ground pin must be the lowest voltage of all pins of the IC at all operating conditions. Ensure that no pins are at a voltage below the ground pin at any time, even during transient condition.
- (5) Thermal consideration  
Use a thermal design that allows for a sufficient margin by taking into account the permissible power dissipation (Pd) in actual operating conditions. Consider Pc that does not exceed Pd in actual operating conditions (Pc≥Pd).

Package Power dissipation : Pd (W)=(Tjmax – Ta) / θ ja  
 Power dissipation : Pc (W)=(Vcc – Vo) × Io + Vcc × Ib

( Tjmax : Maximum junction temperature=150°C, Ta : Peripheral temperature[°C] ,  
 θ ja : Thermal resistance of package-ambience[°C/W], Pd : Package Power dissipation [W],  
 Pc : Power dissipation [W], Vcc : Input Voltage, Vo : Output Voltage, Io : Load, Ib : Bias Current )

- (6) Short between pins and mounting errors  
Be careful when mounting the IC on printed circuit boards. The IC may be damaged if it is mounted in a wrong orientation or if pins are shorted together. Short circuit may be caused by conductive particles caught between the pins.
- (7) Operation under strong electromagnetic field  
Operating the IC in the presence of a strong electromagnetic field may cause the IC to malfunction.
- (8) Area of Safe Operation (ASO)  
Operate the IC such that the output voltage, output current, and power dissipation are all within the Area of Safe Operation (ASO).
- (9) Thermal shutdown circuit (TSD)  
The IC incorporates a built-in thermal shutdown circuit, which is designed to turn off the IC when the internal temperature of the IC reaches a specified value. It is not designed to protect the IC from damage or guarantee its operation. Do not continue to operate the IC after this function is activated. Do not use the IC in conditions where this function will always be activated.

	TSD ON Temperature[□] (typ.)	Hysteresis Temperature [□] (typ.)
BZ1A5001GM	185	15

- (10) Testing on application boards  
When testing the IC on an application board, connecting a capacitor directly to a low-impedance output pin may subject the IC to stress. Always discharge capacitors completely after each process or step. The IC's power supply should always be turned off completely before connecting or removing it from the test setup during the inspection process. To prevent damage from static discharge, ground the IC during assembly and use similar precautions during transport and storage.



(11) Regarding input pin of the IC

This monolithic IC contains P+ isolation and P substrate layers between adjacent elements in order to keep them isolated. P-N junctions are formed at the intersection of the P layers with the N layers of other elements, creating a parasitic diode or transistor. For example (refer to figure below):

When  $GND > Pin A$  and  $GND > Pin B$ , the P-N junction operates as a parasitic diode.  
 When  $GND > Pin B$ , the P-N junction operates as a parasitic transistor.

Parasitic diodes inevitably occur in the structure of the IC. The operation of parasitic diodes can result in mutual interference among circuits, operational faults, or physical damage. Therefore, conditions that cause these diodes to operate, such as applying a voltage lower than the GND voltage to an input pin (and thus to the P substrate) should be avoided.

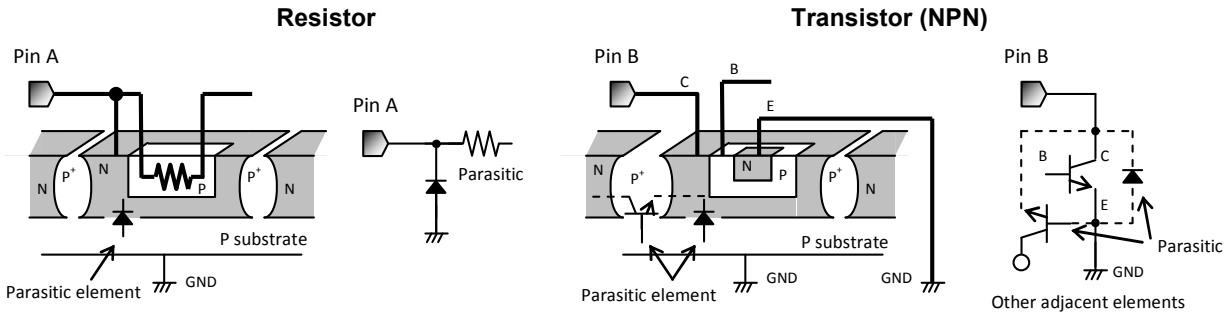

Example of monolithic IC structure

(12) GND wiring pattern

When using both small-signal and large-current GND traces, the two ground traces should be routed separately but connected to a single ground at the reference point of the application board to avoid fluctuations in the small-signal ground caused by large currents. Also ensure that the GND traces of external components do not cause variations on the GND voltage. The power supply and ground lines must be as short and thick as possible to reduce line impedance.

●発注形名情報

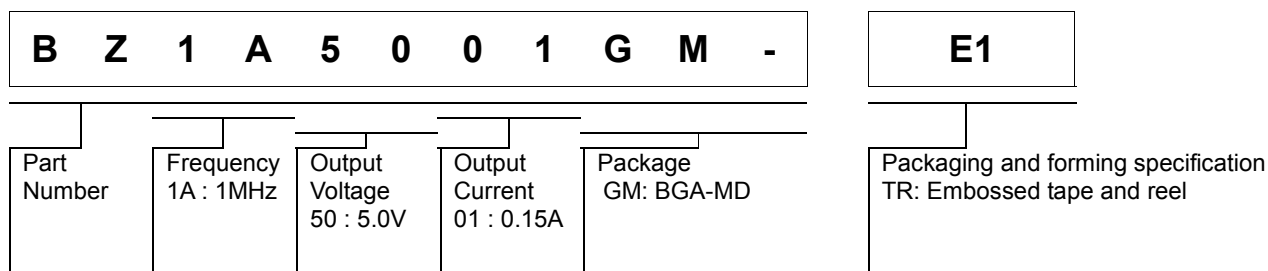

●Package and forming specification

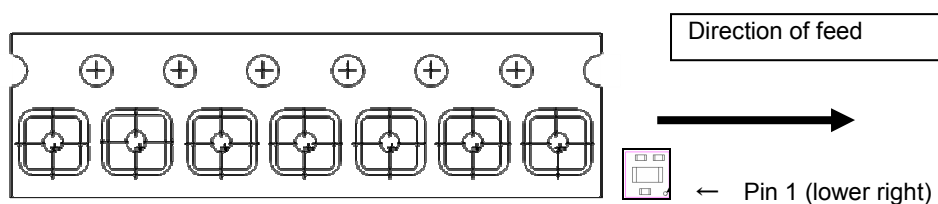

Tape	Embossed career tape
Quantity	9,000pcs
Direction of feed	E1 The location of pin 1 of the product is at the lower right when you hold the reel on the left hand and you pull out the tape on the right hand.

## ●Revision history

Date	Revision	Changes
18.Jan.2013	001	New Release
15.Feb.2013	002	Pin Configuration (Fig-1)

# Notice

## Precaution on using ROHM Products

- Our Products are designed and manufactured for application in ordinary electronic equipments (such as AV equipment, OA equipment, telecommunication equipment, home electronic appliances, amusement equipment, etc.). If you intend to use our Products in devices requiring extremely high reliability (such as medical equipment <sup>(Note 1)</sup>, transport equipment, traffic equipment, aircraft/spacecraft, nuclear power controllers, fuel controllers, car equipment including car accessories, safety devices, etc.) and whose malfunction or failure may cause loss of human life, bodily injury or serious damage to property ("Specific Applications"), please consult with the ROHM sales representative in advance. Unless otherwise agreed in writing by ROHM in advance, ROHM shall not be in any way responsible or liable for any damages, expenses or losses incurred by you or third parties arising from the use of any ROHM's Products for Specific Applications.

(Note1) Medical Equipment Classification of the Specific Applications

JAPAN	USA	EU	CHINA
CLASS III	CLASS III	CLASS II b	CLASS III
CLASS IV		CLASS III	

- ROHM designs and manufactures its Products subject to strict quality control system. However, semiconductor products can fail or malfunction at a certain rate. Please be sure to implement, at your own responsibilities, adequate safety measures including but not limited to fail-safe design against the physical injury, damage to any property, which a failure or malfunction of our Products may cause. The following are examples of safety measures:
  - Installation of protection circuits or other protective devices to improve system safety
  - Installation of redundant circuits to reduce the impact of single or multiple circuit failure
- Our Products are designed and manufactured for use under standard conditions and not under any special or extraordinary environments or conditions, as exemplified below. Accordingly, ROHM shall not be in any way responsible or liable for any damages, expenses or losses arising from the use of any ROHM's Products under any special or extraordinary environments or conditions. If you intend to use our Products under any special or extraordinary environments or conditions (as exemplified below), your independent verification and confirmation of product performance, reliability, etc. prior to use, must be necessary:
  - Use of our Products in any types of liquid, including water, oils, chemicals, and organic solvents
  - Use of our Products outdoors or in places where the Products are exposed to direct sunlight or dust
  - Use of our Products in places where the Products are exposed to sea wind or corrosive gases, including Cl<sub>2</sub>, H<sub>2</sub>S, NH<sub>3</sub>, SO<sub>2</sub>, and NO<sub>2</sub>
  - Use of our Products in places where the Products are exposed to static electricity or electromagnetic waves
  - Use of our Products in proximity to heat-producing components, plastic cords, or other flammable items
  - Sealing or coating our Products with resin or other coating materials
  - Use of our Products without cleaning residue of flux (even if you use no-clean type fluxes, cleaning residue of flux is recommended); or Washing our Products by using water or water-soluble cleaning agents for cleaning residue after soldering
  - Use of the Products in places subject to dew condensation
- The Products are not subject to radiation-proof design.
- Please verify and confirm characteristics of the final or mounted products in using the Products.
- In particular, if a transient load (a large amount of load applied in a short period of time, such as pulse. is applied, confirmation of performance characteristics after on-board mounting is strongly recommended. Avoid applying power exceeding normal rated power; exceeding the power rating under steady-state loading condition may negatively affect product performance and reliability.
- De-rate Power Dissipation (Pd) depending on Ambient temperature (Ta). When used in sealed area, confirm the actual ambient temperature.
- Confirm that operation temperature is within the specified range described in the product specification.
- ROHM shall not be in any way responsible or liable for failure induced under deviant condition from what is defined in this document.

## Precaution for Mounting / Circuit board design

- When a highly active halogenous (chlorine, bromine, etc.) flux is used, the residue of flux may negatively affect product performance and reliability.
- In principle, the reflow soldering method must be used; if flow soldering method is preferred, please consult with the ROHM representative in advance.

For details, please refer to ROHM Mounting specification

**Precautions Regarding Application Examples and External Circuits**

1. If change is made to the constant of an external circuit, please allow a sufficient margin considering variations of the characteristics of the Products and external components, including transient characteristics, as well as static characteristics.
2. You agree that application notes, reference designs, and associated data and information contained in this document are presented only as guidance for Products use. Therefore, in case you use such information, you are solely responsible for it and you must exercise your own independent verification and judgment in the use of such information contained in this document. ROHM shall not be in any way responsible or liable for any damages, expenses or losses incurred by you or third parties arising from the use of such information.

**Precaution for Electrostatic**

This Product is electrostatic sensitive product, which may be damaged due to electrostatic discharge. Please take proper caution in your manufacturing process and storage so that voltage exceeding the Products maximum rating will not be applied to Products. Please take special care under dry condition (e.g. Grounding of human body / equipment / solder iron, isolation from charged objects, setting of ionizer, friction prevention and temperature / humidity control).

**Precaution for Storage / Transportation**

1. Product performance and soldered connections may deteriorate if the Products are stored in the places where:
  - [a] the Products are exposed to sea winds or corrosive gases, including Cl<sub>2</sub>, H<sub>2</sub>S, NH<sub>3</sub>, SO<sub>2</sub>, and NO<sub>2</sub>
  - [b] the temperature or humidity exceeds those recommended by ROHM
  - [c] the Products are exposed to direct sunshine or condensation
  - [d] the Products are exposed to high Electrostatic
2. Even under ROHM recommended storage condition, solderability of products out of recommended storage time period may be degraded. It is strongly recommended to confirm solderability before using Products of which storage time is exceeding the recommended storage time period.
3. Store / transport cartons in the correct direction, which is indicated on a carton with a symbol. Otherwise bent leads may occur due to excessive stress applied when dropping of a carton.
4. Use Products within the specified time after opening a humidity barrier bag. Baking is required before using Products of which storage time is exceeding the recommended storage time period.

**Precaution for Product Label**

QR code printed on ROHM Products label is for ROHM's internal use only.

**Precaution for Disposition**

When disposing Products please dispose them properly using an authorized industry waste company.

**Precaution for Foreign Exchange and Foreign Trade act**

Since our Products might fall under controlled goods prescribed by the applicable foreign exchange and foreign trade act, please consult with ROHM representative in case of export.

**Precaution Regarding Intellectual Property Rights**

1. All information and data including but not limited to application example contained in this document is for reference only. ROHM does not warrant that foregoing information or data will not infringe any intellectual property rights or any other rights of any third party regarding such information or data. ROHM shall not be in any way responsible or liable for infringement of any intellectual property rights or other damages arising from use of such information or data.:
2. No license, expressly or implied, is granted hereby under any intellectual property rights or other rights of ROHM or any third parties with respect to the information contained in this document.

**Other Precaution**

1. This document may not be reprinted or reproduced, in whole or in part, without prior written consent of ROHM.
2. The Products may not be disassembled, converted, modified, reproduced or otherwise changed without prior written consent of ROHM.
3. In no event shall you use in any way whatsoever the Products and the related technical information contained in the Products or this document for any military purposes, including but not limited to, the development of mass-destruction weapons.
4. The proper names of companies or products described in this document are trademarks or registered trademarks of ROHM, its affiliated companies or third parties.

**General Precaution**

1. Before you use our Products, you are requested to carefully read this document and fully understand its contents. ROHM shall not be in any way responsible or liable for failure, malfunction or accident arising from the use of any ROHM's Products against warning, caution or note contained in this document.
2. All information contained in this document is current as of the issuing date and subject to change without any prior notice. Before purchasing or using ROHM's Products, please confirm the latest information with a ROHM sales representative.
3. The information contained in this document is provided on an "as is" basis and ROHM does not warrant that all information contained in this document is accurate and/or error-free. ROHM shall not be in any way responsible or liable for any damages, expenses or losses incurred by you or third parties resulting from inaccuracy or errors of or concerning such information.